

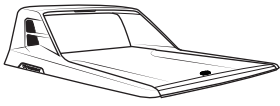









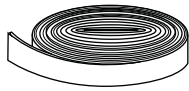
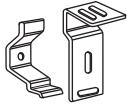

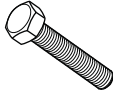







อุปกรณ์ในการติดตั้ง / INSTALLATION PARTS

 <p>SPORT LID 1 set. ฝาครอบกระบะ 1 ชุด</p>	<p>1</p>  <p>Plastic packaging 1 pc. ถุงบรรจุชุดติดตั้ง 1 ใบ C-130004</p>	<p>2</p>  <p>Sponge rubber edge 1 roll. ยางฟองน้ำติดขอบ 1 ม้วน C-020145</p>	<p>3</p>  <p>Kwick klamp 1 set. ชุดควิกแคลมป์ 1 ชุด V-120522-01</p>	<p>4</p>  <p>Battery AAA 4 pcs. ถ่าน AAA 4 ก้อน C-240179</p>
<p>5</p>  <p>Logo CARRYBOY 1 pc. ป้ายโลโก้ CARRYBOY 1 อัน C-110535C</p>	<p>6</p>  <p>Bolt M8x40 zing black 6 pcs. โบลท์ M8x40 ชิงค์ดำ 6 ตัว C-030620</p>	<p>7</p>  <p>Washer M8 zing black 6 pcs. แหวนอีแปะ M8 ชิงค์ดำ 6 ตัว C-030616</p>	<p>8</p>  <p>Spring washer M8 zing black 6 pcs. แหวนสปริง M8 ชิงค์ดำ 6 ตัว C-030617</p>	<p>9</p>  <p>Bolt M6x25 zing black 12 pcs. โบลท์ M6x25 ชิงค์ดำ 12 ตัว C-030613</p>
<p>10</p>  <p>Washer M6 zing black 12 pcs. แหวนอีแปะ M6 ชิงค์ดำ 12 ตัว C-030608</p>	<p>11</p>  <p>Spring washer M6 zing black 12 pcs. แหวนสปริง M6 ชิงค์ดำ 12 ตัว C-030610</p>	<p>12</p>  <p>Tapping screw SUS.JP8-1/2 2 pcs. สกรูเกลียวปลายลอย SUS.JP8-1/2 2 ตัว C-030059</p>	<p>13</p>  <p>Black Silicone 1 pc. ซิลิโคนสีดำ 1 หลอด C-070024</p>	<p>14</p>  <p>Electric clamp lock 2 pcs. แคลมป์ล็อกสายไฟ 2 อัน C-160259</p>
<p>15</p>  <p>Cable tie 5.5 15 pcs. เดบีลไทร์สีขาว 5.5 15 เส้น C-130046</p>	<p>16</p>  <p>ST.ATTENTION 5000 KM. 1 pc. ป้ายคำเตือน 1 แผ่น V-140163</p>	<p>17</p>  <p>Installation manual 1 pc. กระดาษวิธีการติดตั้ง 1 แผ่น C-132687-28</p>	<p>18</p>  <p>Check list 1 pc. ใบเช็ครายการชุดติดตั้ง 1 แผ่น CL-280031-55/56</p>	

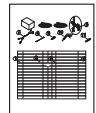
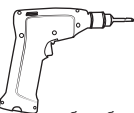
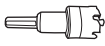
เครื่องมือในการติดตั้ง / INSTALLATION TOOLS

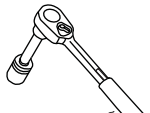
 <p>สกรูไดร์เวอร์ Screw Driver</p>	 <p>ดอกเจาะโฮลซอร์ว ๕ 40 Hole saw ๕ 40</p>	 <p>ประแจ No.10,12,13,17 Wrench No.10,12,13,17</p>	 <p>ดอกสว่าน ๕ 3.5, ๕ 4, ๕ 5 Drill ๕ 3.5, ๕ 4, ๕ 5</p>	 <p>ประแจทอร์ก Torque Wrench</p>	 <p>ตลับเมตร Measuring tape</p>	 <p>คัตเตอร์ Cutter</p>	 <p>ปืนซิลิโคน Caulking Gun</p>
--	---	---	---	--	--	--	--

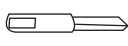
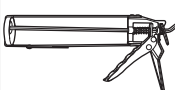
- 1** If install with liner, drill 2 connection holes with hole saw \varnothing 40 mm. See the drawing for appropriate dimension to drill.
กรณี มีไลน์เนอร์เจาะรูไลน์เนอร์ 2 รูต่อกันด้วยโฮลซอร์ว \varnothing 40 มม. ดังรูป

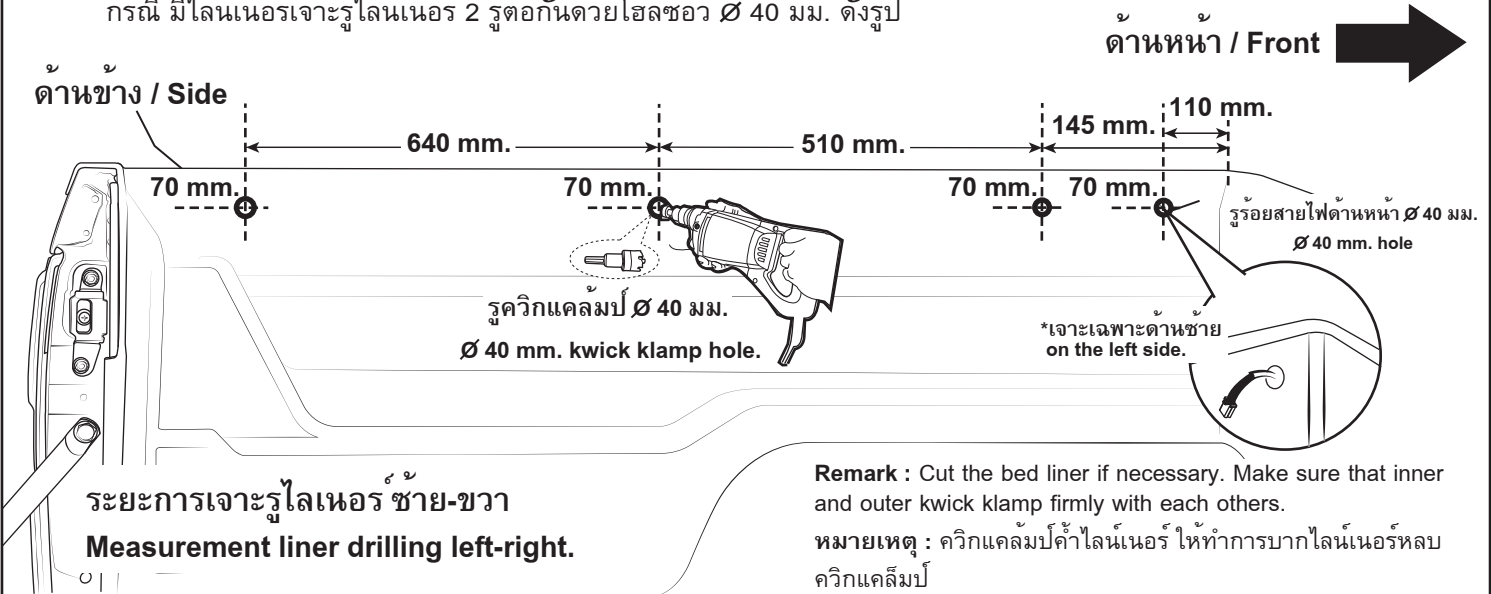

- 2** Clean the edge of truck bed. Install rubber truck edge on the truck bed left right and front.
ทำความสะอาดบริเวณหัวแกงและขอบกระบะติดยางขอบกระบะด้านซ้ายด้านขวาและด้านหน้า

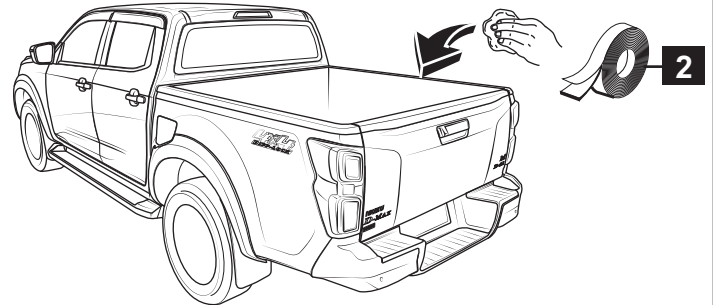
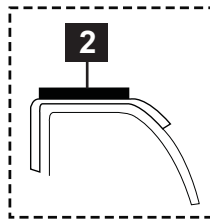

- 3** Place hardtop on the truck bed and adjust alignment between left and right.
ยกฝาครอบกระบะวางบนลูกกระบะ จัดระยะความกว้างยาวให้พอดีกับลูกกระบะ

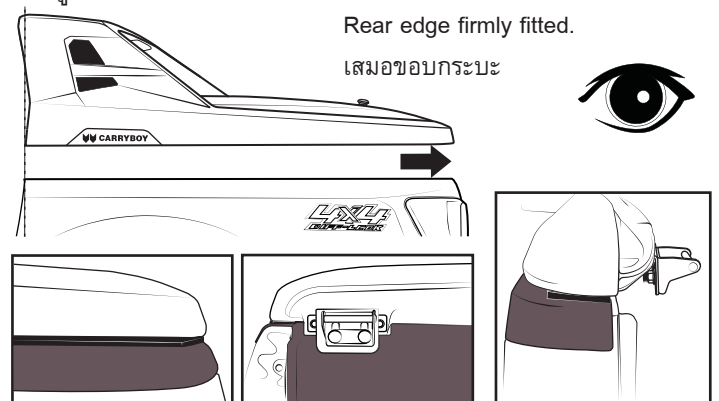
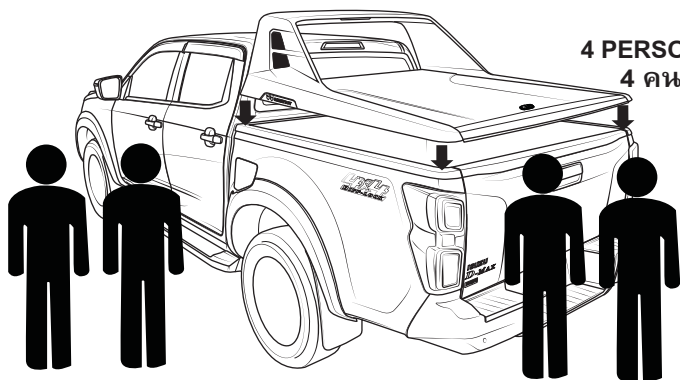

- 4** Install kwick klamp for 6 positions.
ติดตั้งควิกแคลมป์ 6 ตำแหน่ง

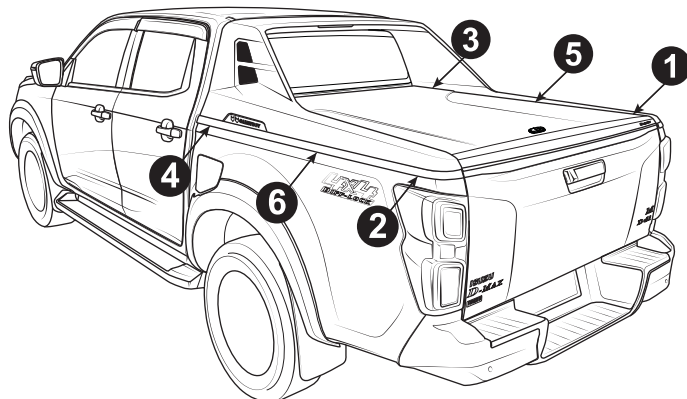
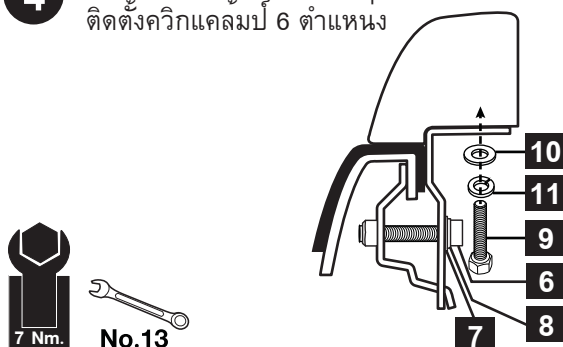

5 Adjust a latch R/L for matching with the rotary lock on the rear door.
ขั้นตอนการปรับแต่งเป็นรับชุดล็อคกลอนฝาท้าย

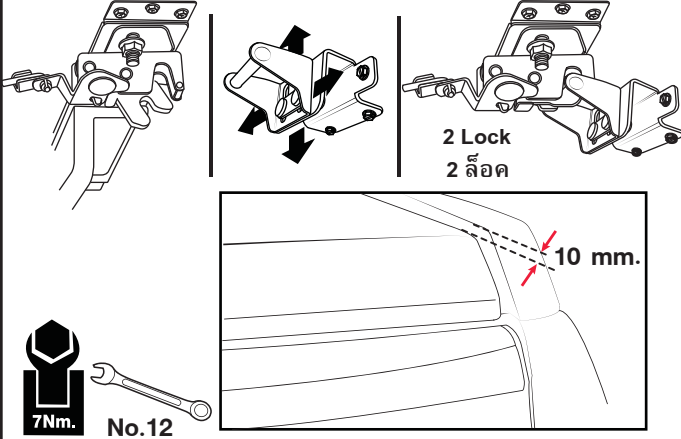

6 Glue the silicone to protect water leaking left-right.
ซิลิโคนรอบขอบกระเบื้องซ้าย-ขวา

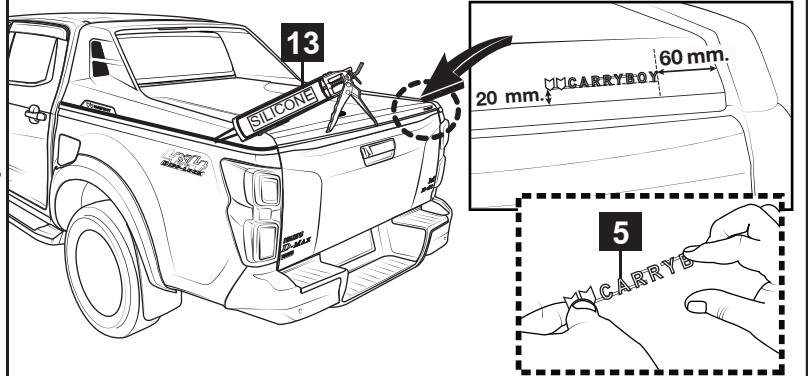

Label drops resin CARRYBOY follow the diagram.
ขั้นตอนการติดป้ายหยอดเรซิน CARRYBOY

7 560-580 mm.
DETAIL 10

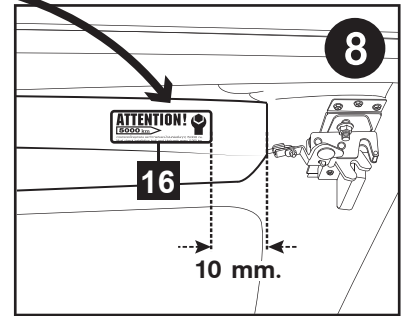
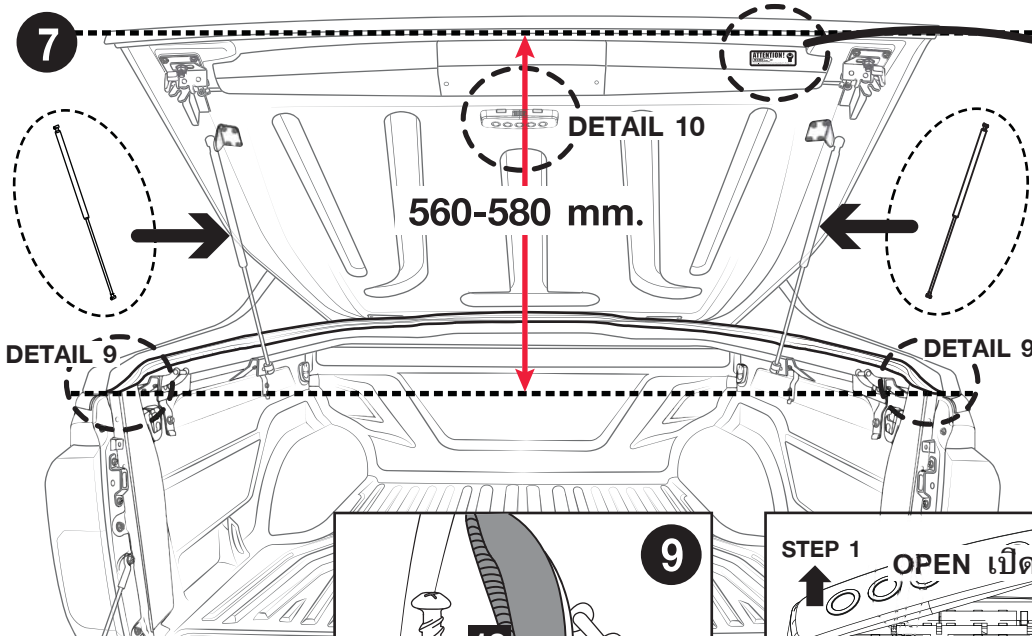

The color shot tapping screw. And silicone seals at the ends of bones.
กรณีสีพื้น ยิงสกรูเกลียวปลอก และซิลิโคนที่ปลายกระดูกงู

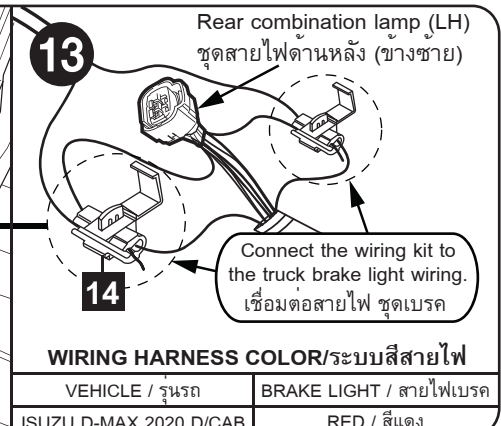
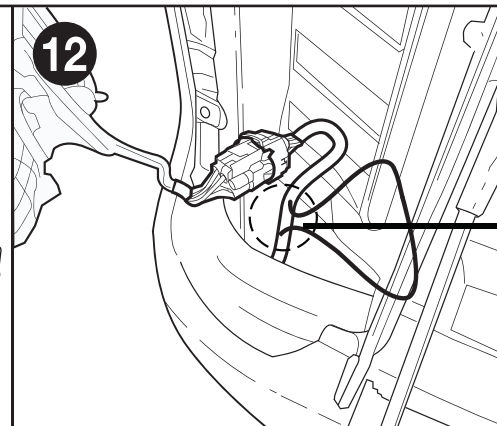
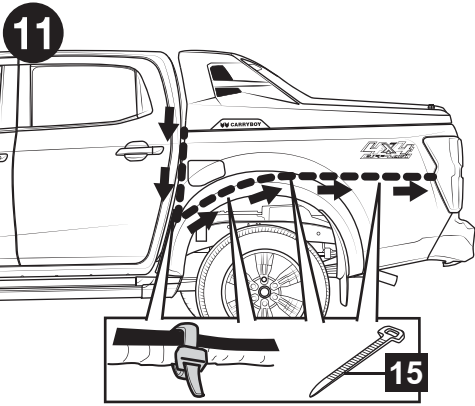
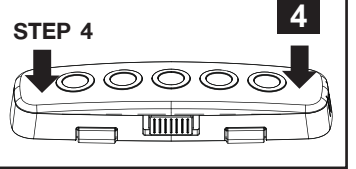
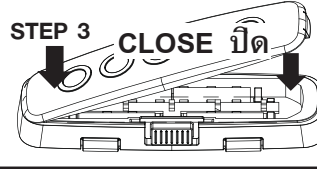
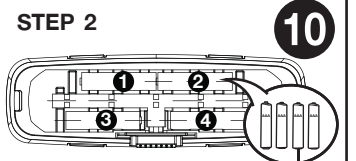
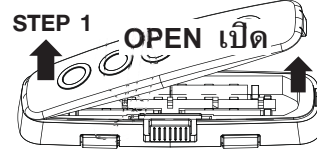
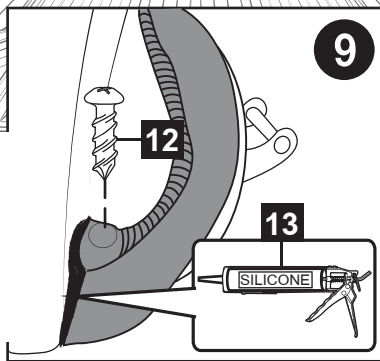

WIRING HARNESS COLOR/ระบบสีสายไฟ

VEHICLE / รุ่นรถ	BRAKE LIGHT / สายไฟเบรค
ISUZU D-MAX 2020 D/CAB	RED / สีแดง