

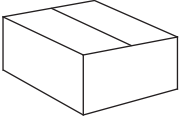

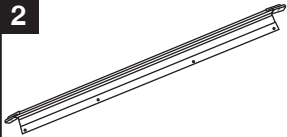









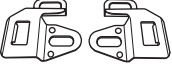



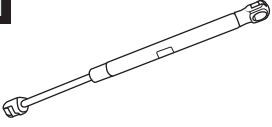
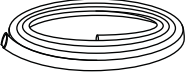



INSTALLATION PARTS

<p>1</p>  <p>Installation kit box 1 pc. C-130043</p>	<p>2</p>  <p>Aluminum CNPD 1 set. M-041491B-01</p>	<p>3</p>  <p>Sponge rubber edge 1 roll. C-020494-04T</p>	<p>4</p>  <p>Kwick klamp S6 1 set. C-120490-02</p>	<p>5</p>  <p>Kwick klamp cover 6 pcs. C-100597-01BL</p>
<p>6</p>  <p>Latch STL S-5 R/L 1 pair. C-110060</p>	<p>7</p>  <p>Double bolt M8x33 SUS 2 pcs. C-120108S</p>	<p>8</p>  <p>PVC Double bolt washer 2 pcs. C-020221V</p>	<p>9</p>  <p>Nut M8 SUS 4 pcs. C-030645</p>	<p>10</p>  <p>AL adjustable shim for latch 2 pcs. C-110160</p>
<p>11</p>  <p>Shock STABILUS GAS 2 pcs. C-160204</p>	<p>12</p>  <p>Weather strip 1 roll. C-020132</p>	<p>13</p>  <p>Screw 2 pcs. C-030059</p>	<p>14</p>  <p>CARRYBOY SR5 LOGO 2 pcs. C-160416-01</p>	<p>15</p>  <p>Wiring harness 1 set. C-090437-02(Front) or C-090437-06(Rear)</p>
<p>15</p>  <p>Box switch 1 pc. C-100341N</p>	<p>16</p>  <p>Cable tie 5.5" 15 pcs. C-130046</p>	<p>17</p>  <p>Electric klamp lock 4 pcs. C-160259</p>	<p>18</p>  <p>Installation manual 1 set. C-132701-06</p>	<p>19</p>  <p>Check list 1 pc. CL-280045-09</p>

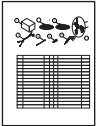
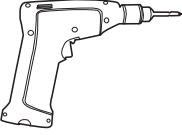
INSTALLATION TOOLS

 <p>Screw Driver</p>	 <p>Torque Wrench No.13</p>	 <p>Wrench No.13</p>	 <p>Cutter</p>	 <p>Measuring tape</p>
---	--	---	---	---

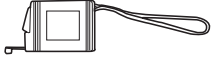
1

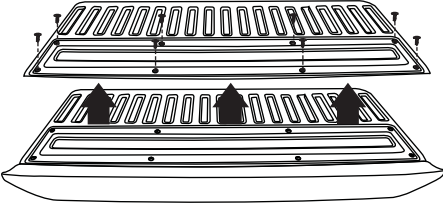

A Remove the tail gate metal sheet.

2

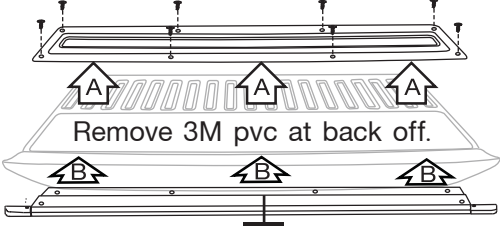

Remove 3M pvc at back off.

B Assemble the rear aluminium profile by through the existing holes and cover both ends with plastic caps.

3

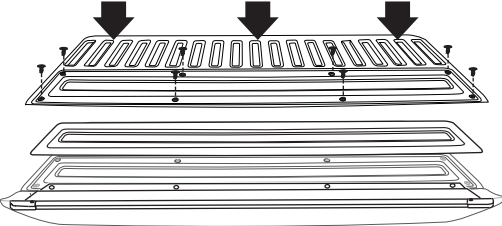

C Tight the tail gate metal sheet back to a truck tail gate.

2 Clean the edge of truck bed and clean of under the hardtop.

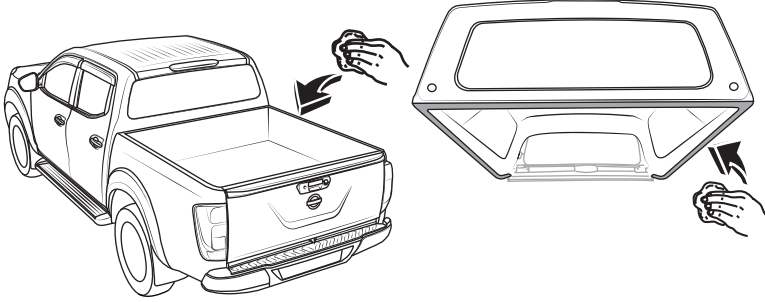

3 Install rubber truck edge under the hardtop.

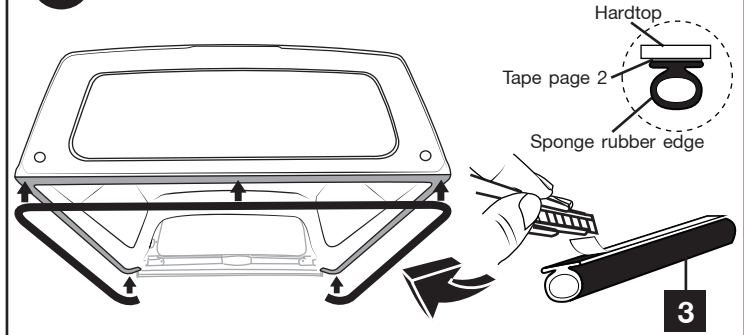

4 Place hardtop on the truck bed and adjust alignment between left and right.

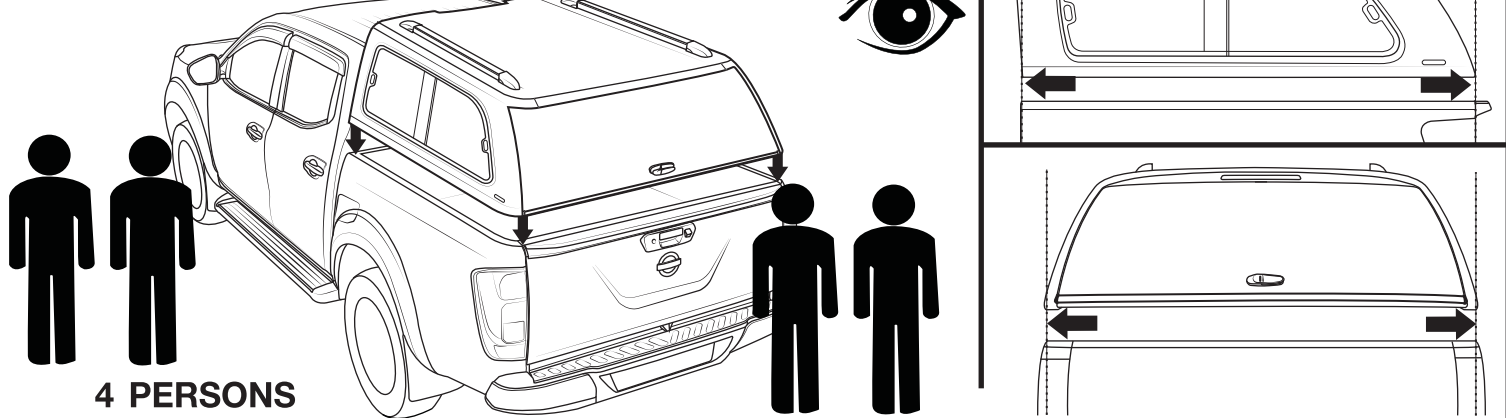

5 Install kwick klamp for 6 positions.

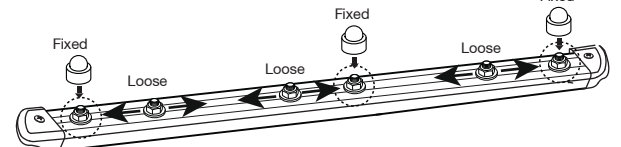
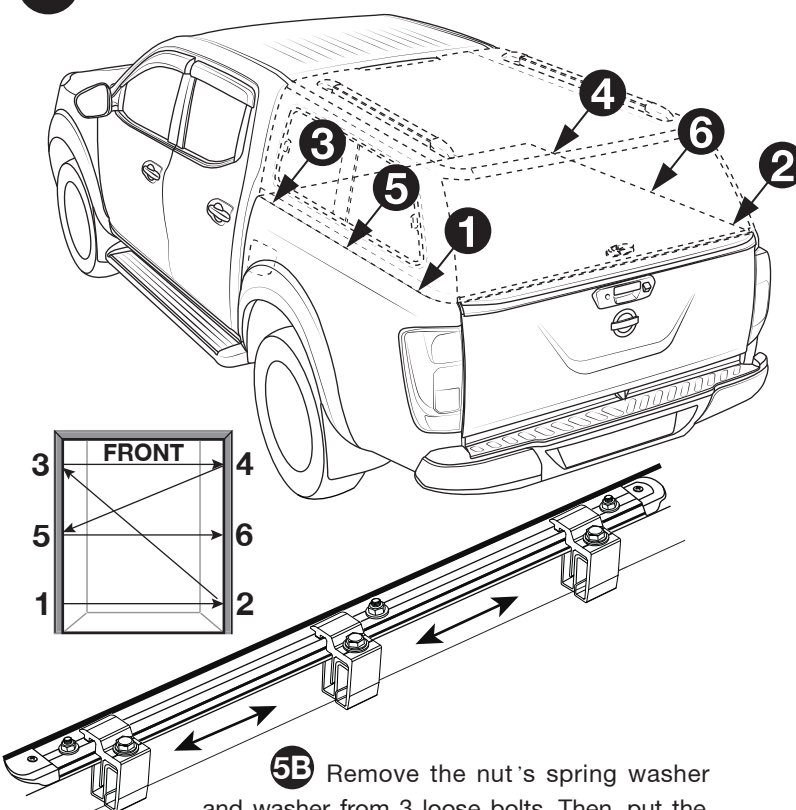

5A Adjust the position to fix loose bolts on the Al. rail. (Remarks : In case of having bed liner, Al. Klamp must be fixed at the flat area of the bed liner)

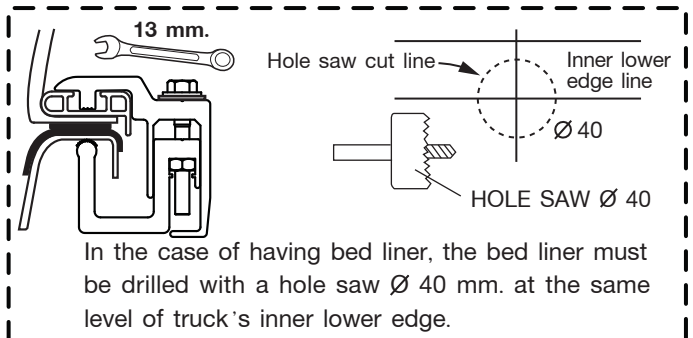

In the case of having bed liner, the bed liner must be drilled with a hole saw $\varnothing 40$ mm. at the same level of truck's inner lower edge.

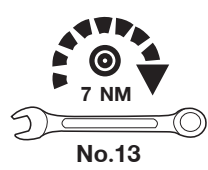

5B Remove the nut's spring washer and washer from 3 loose bolts. Then, put the upper Al. clomp klamp on the Al. rail through the hole on the top of upper Al. klamp. Tighter nuts, spring washer and washer back to its original position to lock the upper Al. klamp.

5C Put the lower Al. klamp through the bolt M8x70 follow the diagram. Then, tighten the lower Al. klamp with truck's inner lower edge and bolt M8x70.

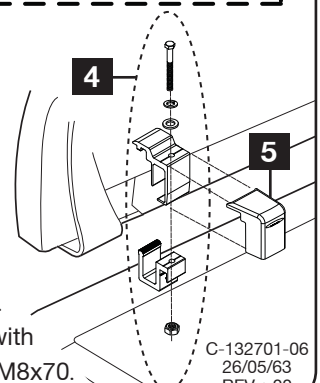

6 Installing latch R/L on the rear door.

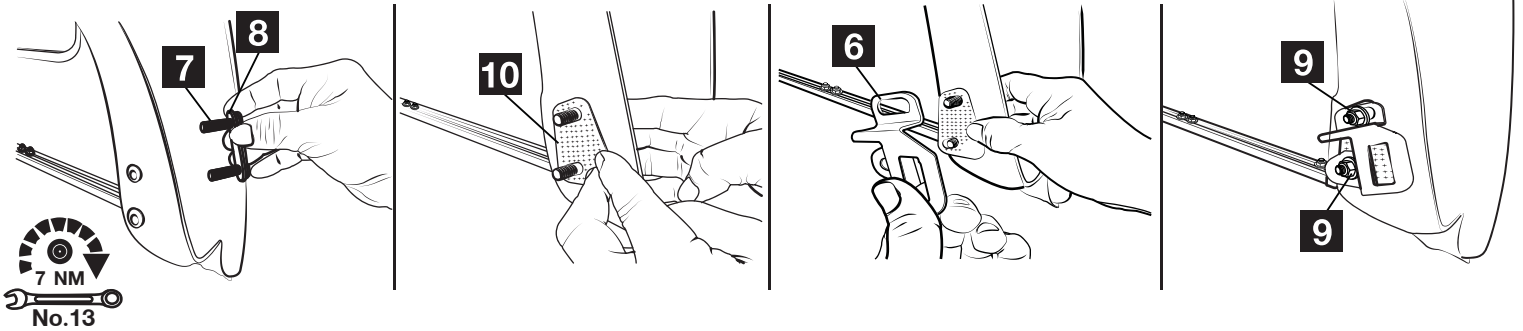

7 Adjust a latch R/L for matching with the slam lock on the rear door.

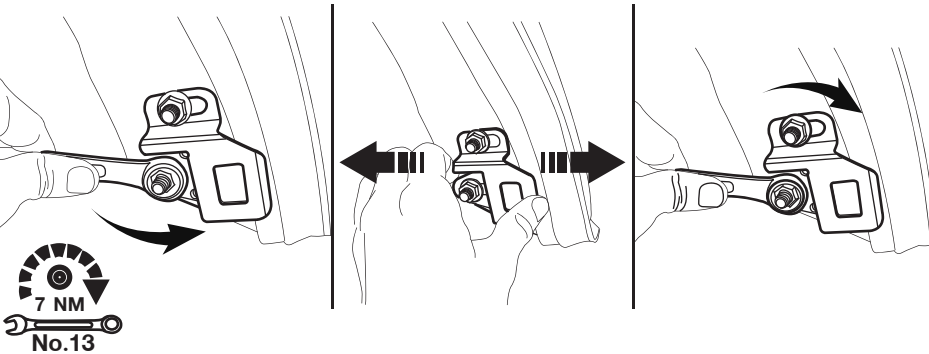

8 Shock absorber assembly.

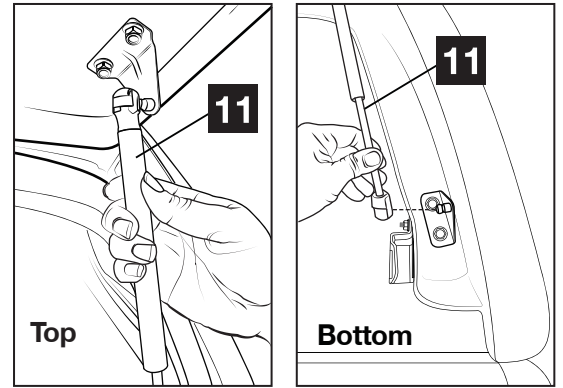

9 Final check the appearance.

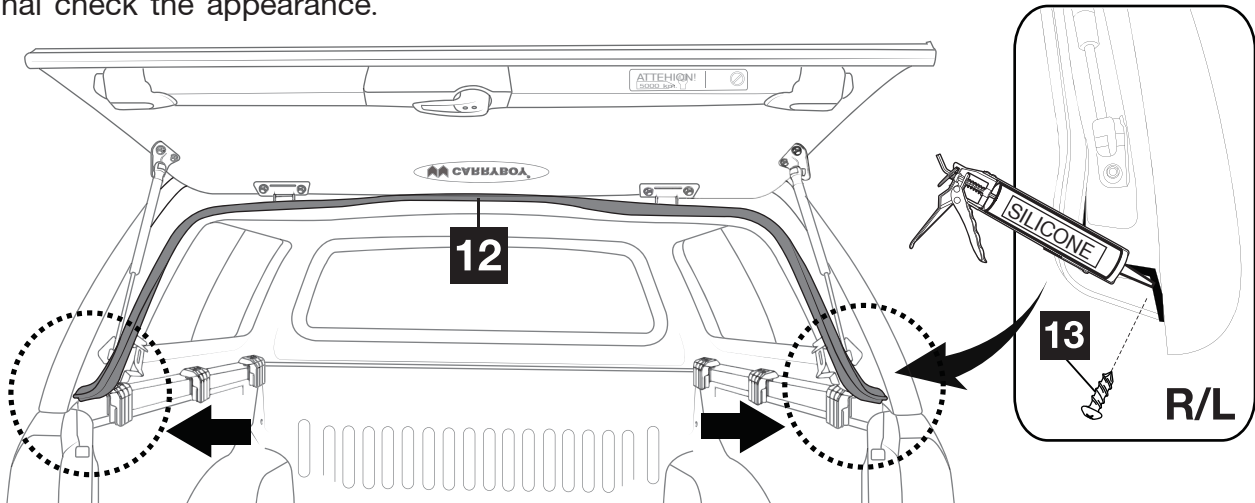

10 Stick logo CARRYBOY SR5 R/L.

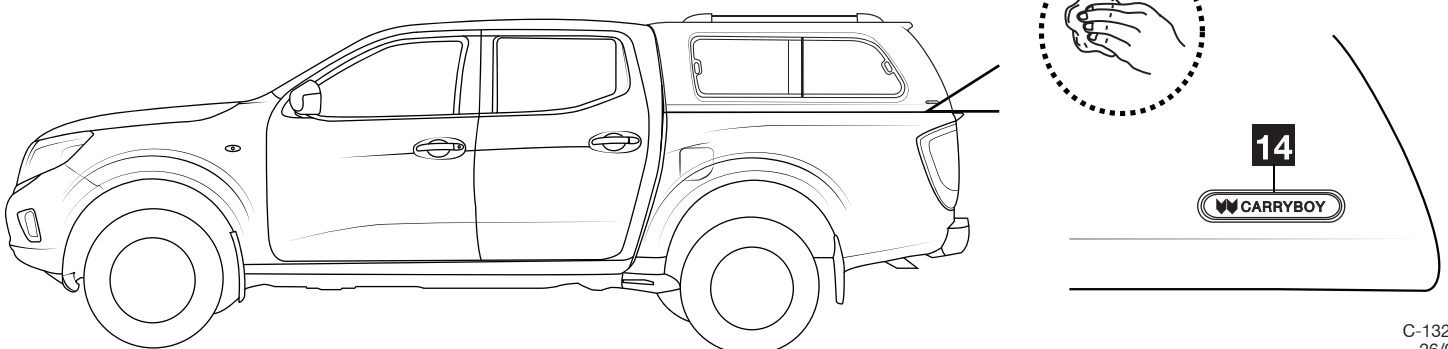

Wiring diagram (Front harness)

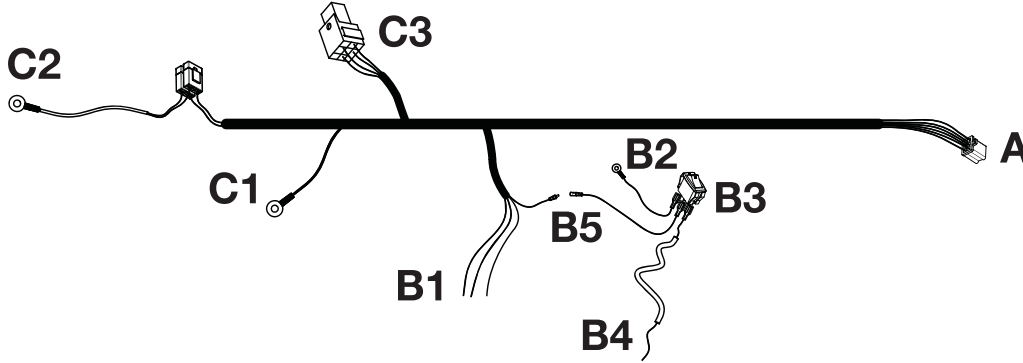

C-090437-02

- Brake
- Room Lamp
- Remote
- Defogger

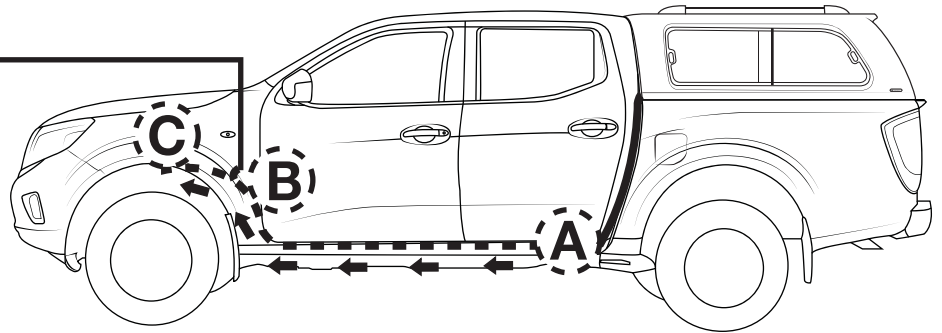
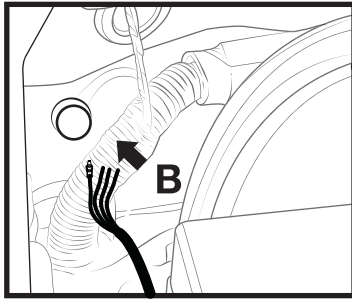

DIAGRAM

- Fuse**
- 15A - Defogger
 - Brake
 - 10A - Room lamp

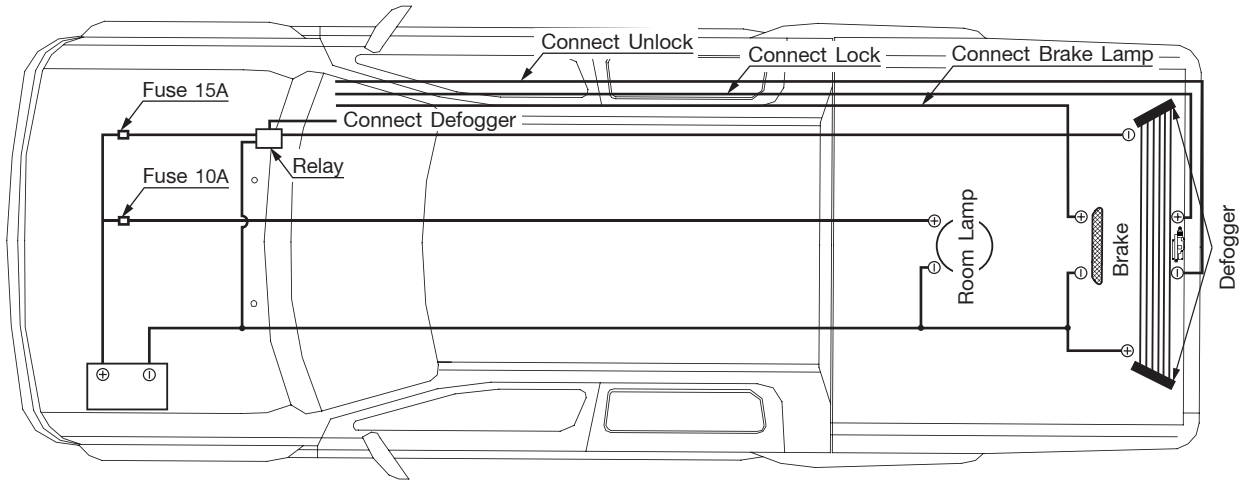

Detail A

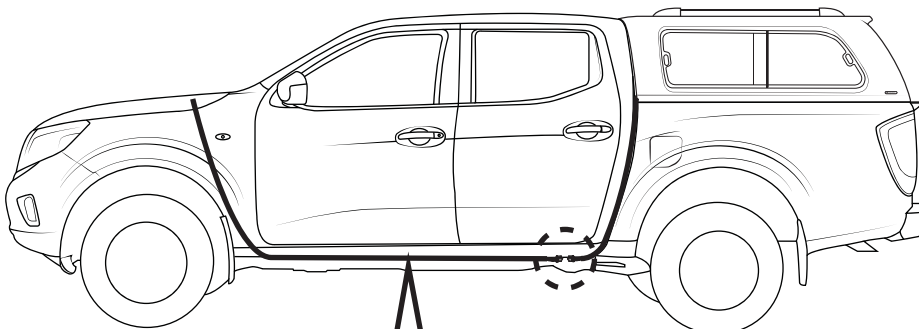

Connection wiring harness to the wiring hardtop.

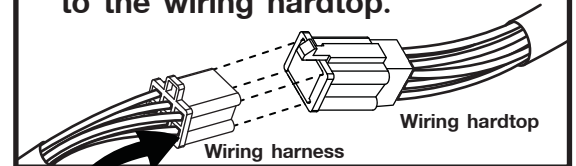

DETAIL A

①	Black	1.50	SQMM
②	Red	1.25	SQMM
③	Green	0.5	SQMM
④	Yellow	0.5	SQMM
⑤	Blue	0.5	SQMM
⑥	White	0.5	SQMM

BACK VIEW



Detail B

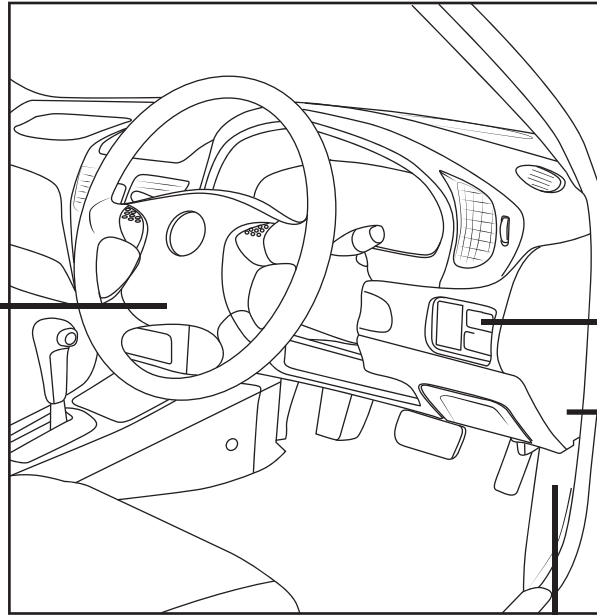
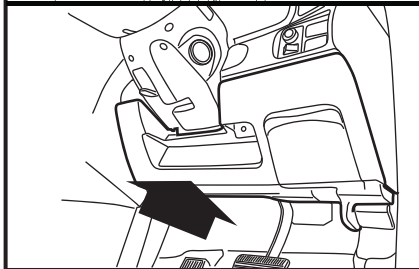
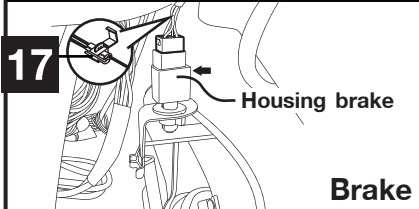
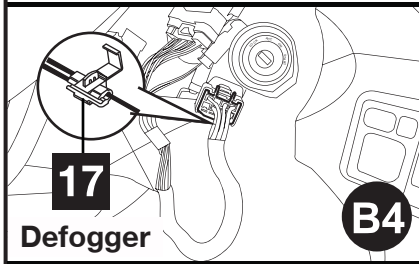
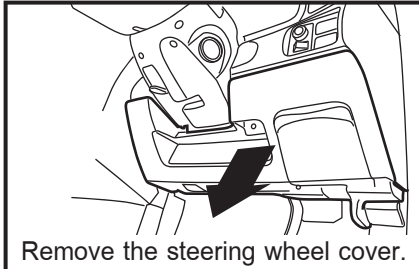

	Car	Wiring harness
Brake	White	Blue
Room Lamp	Battery +	(Ring)
Defogger	Green-Bronze	Red
Lock	Light blue-Bronze	Green
Unlock	Pink-Bronze	Yellow

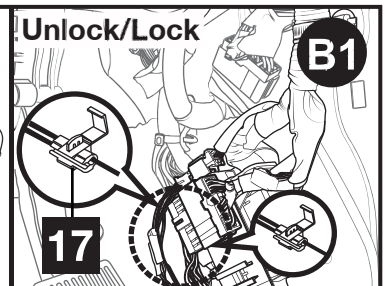
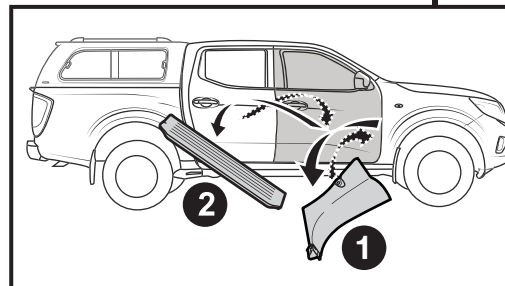
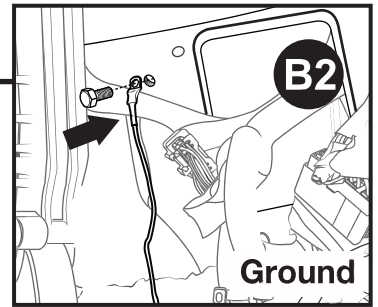
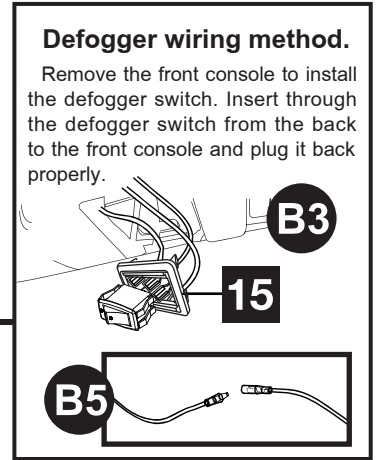

Detail C

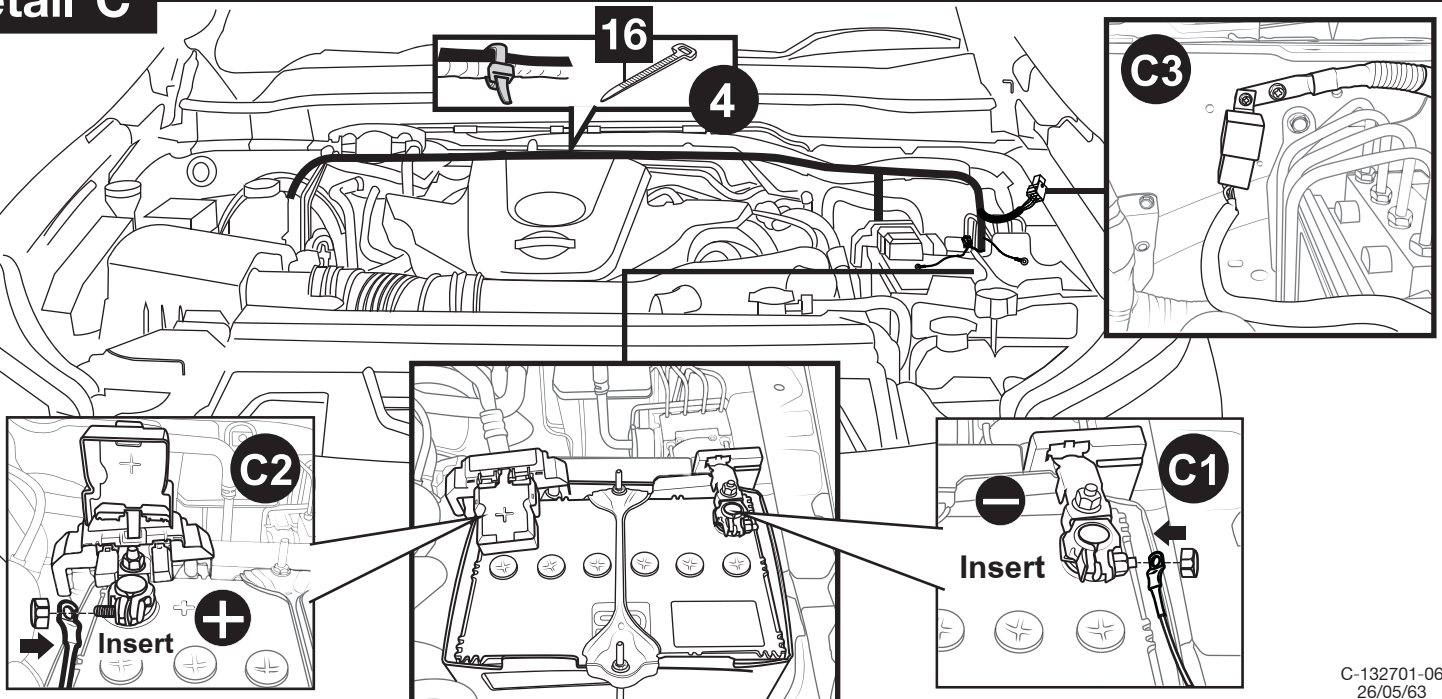

Wiring diagram (Rear harness)

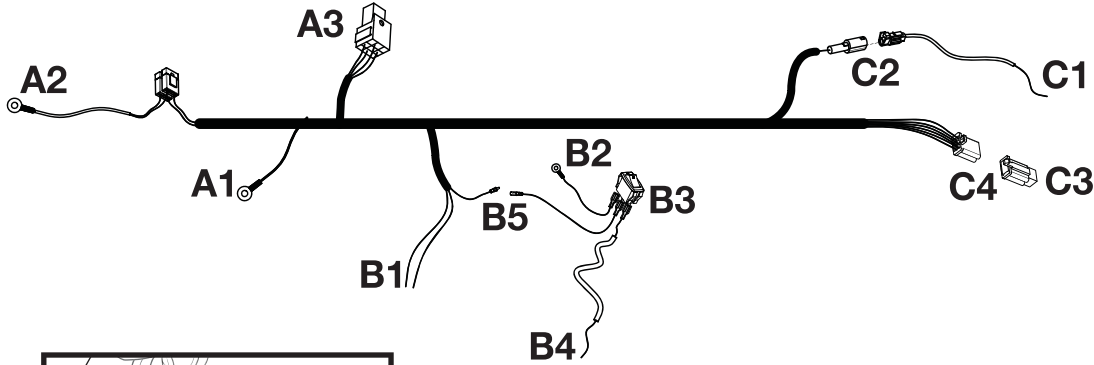

C-090437-06

- Brake
- Room Lamp
- Remote
- Defogger

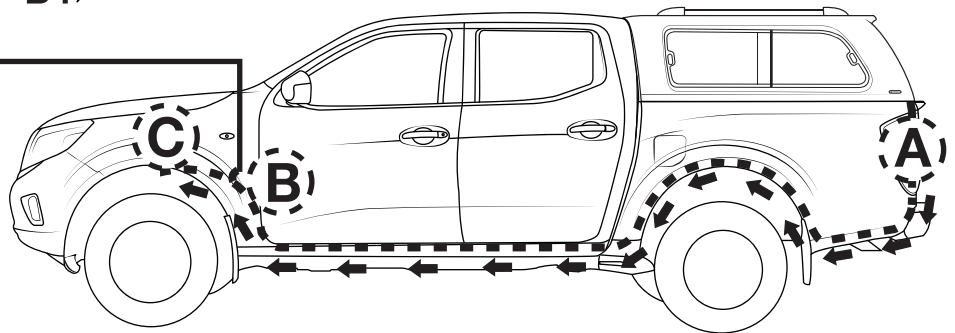
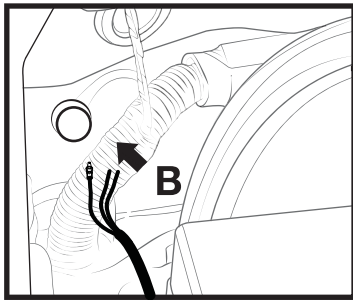

DIAGRAM

- Fuse**
- 15A - Defogger
 - Brake
 - 10A - Room lamp

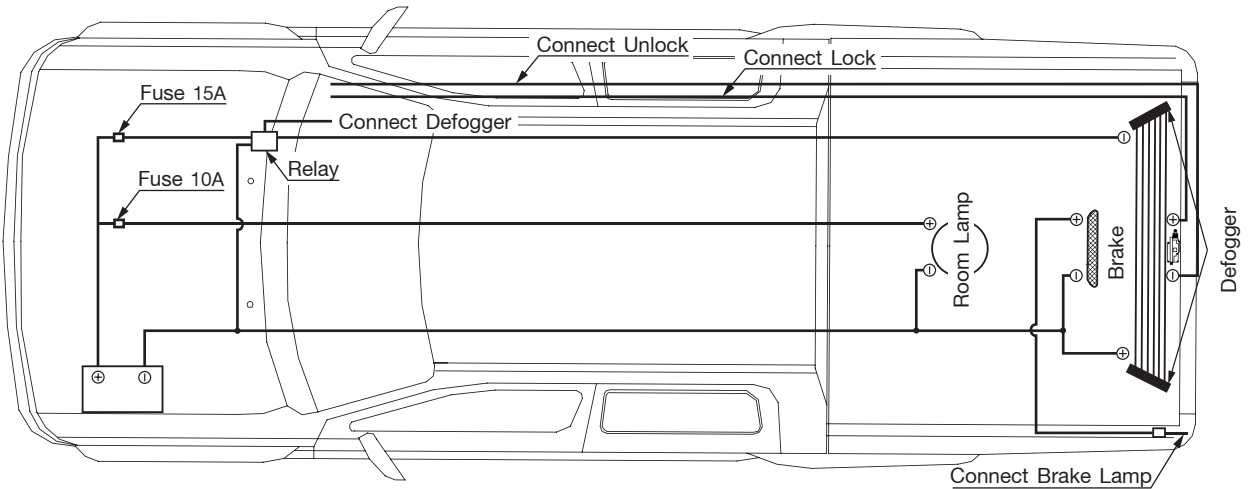

Detail A

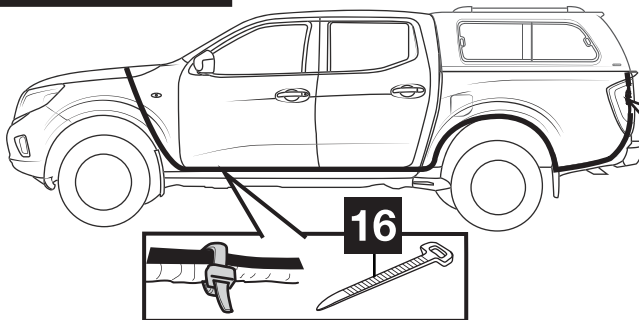

Remove tail lamp

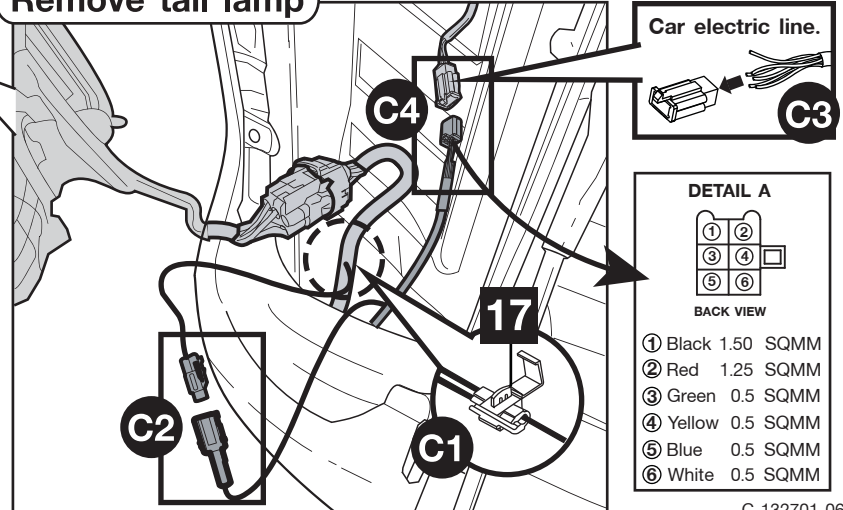

Car electric line.

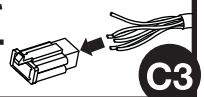

DETAIL A



BACK VIEW

- ① Black 1.50 SQMM
- ② Red 1.25 SQMM
- ③ Green 0.5 SQMM
- ④ Yellow 0.5 SQMM
- ⑤ Blue 0.5 SQMM
- ⑥ White 0.5 SQMM

	Car	Wiring harness
Brake	Yellow	Blue
Room Lamp	Battery +	(Ring)
Defogger	Green-Bronze	Red
Lock	Light blue-Bronze	Green
Unlock	Pink-Bronze	Yellow

Detail B

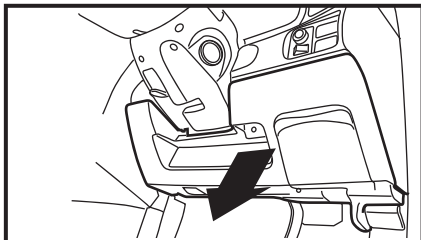

Remove the steering wheel cover.

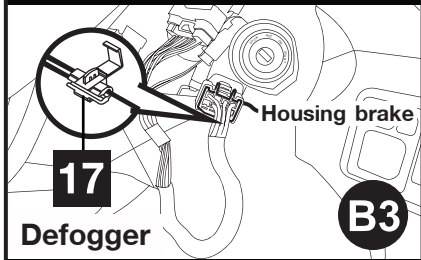

Defogger

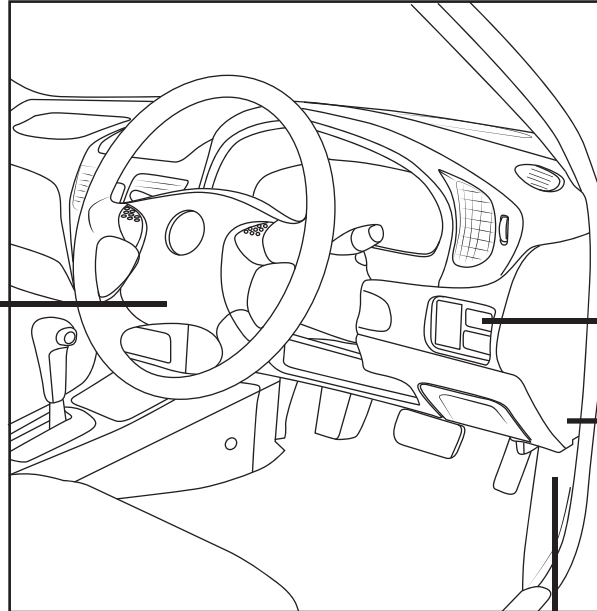
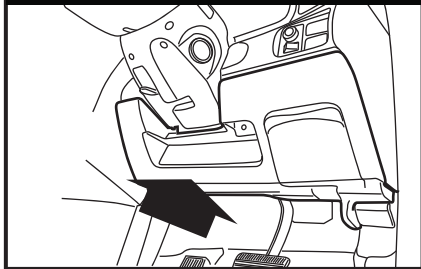

Defogger wiring method.

Remove the front console to install the defogger switch. Insert through the defogger switch from the back to the front console and plug it back properly.

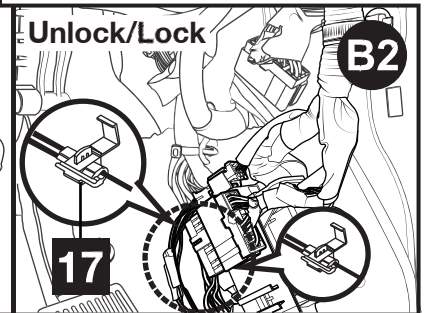
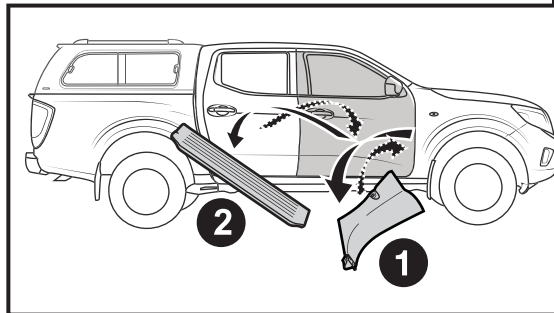
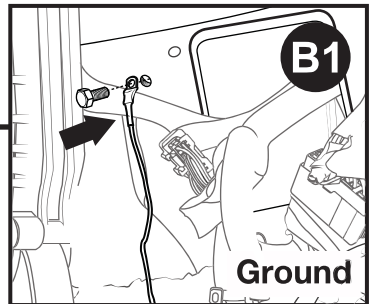
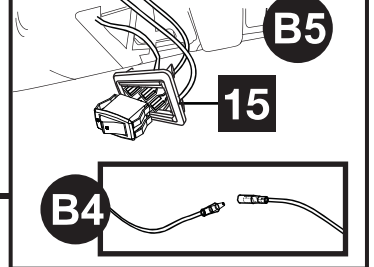

Detail C

