

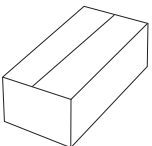









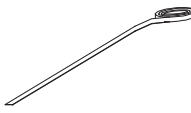

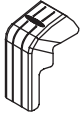
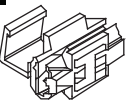
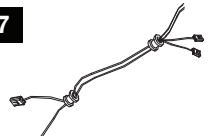
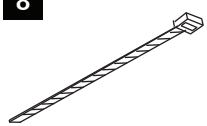
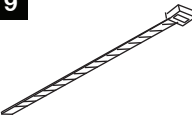

INSTALLATION G3E

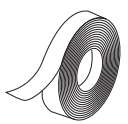
PARTS

<b>1</b>  Spare part carton	<b>2</b>  Weatherstrip #205/2	<b>3</b>  Sponge Seal	<b>4</b>  S4 AL. Kwick Klamp	<b>5</b>  Kwick Klamp Cover
<b>6</b>  Electric klamp lock	<b>7</b>  Wiring kit	<b>8</b>  Black Cable Tie	<b>9</b>  White Cable Tie	<b>10</b>  Adaptor Switch
<b>11</b>  JP 8-1/2 EDP Screw	<b>12</b>  JP 2x1/4 Screw	<b>13</b>  Remote Control Set	<b>14</b>  2.5m. Double Side Tape	<b>15</b>  Carryboy Resin Plate
<b>16</b>  Bushing	<b>17</b>  Gas Strut Sticker	<b>18</b>  Ball Strut	<b>19</b>  Installation Manual	<b>20</b>  Installation Check List

**A** Clean the surface of the truck top edge .

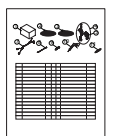
**B** Place the sponge seal the truck top edge.

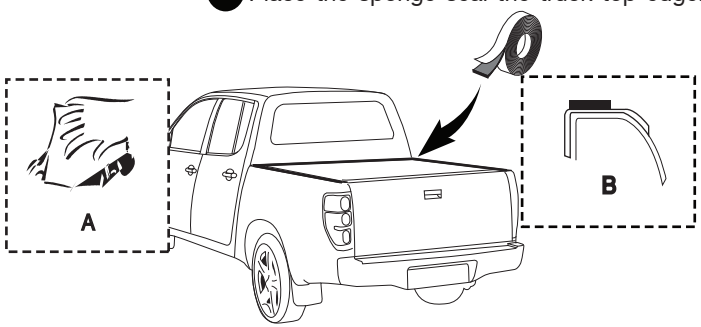

**C** Put the hardtop on top for the sponge seal and align left and right properly.

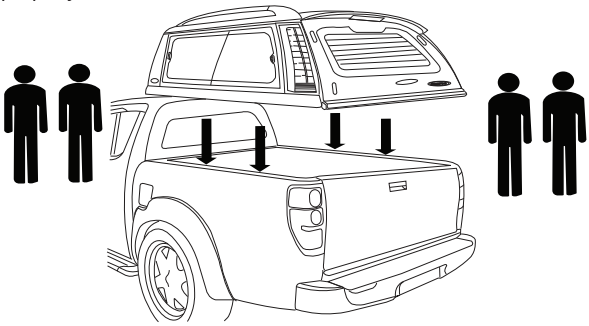

**D** Install kwick klamp at 6 position points. (DETAIL A and DETAIL B)

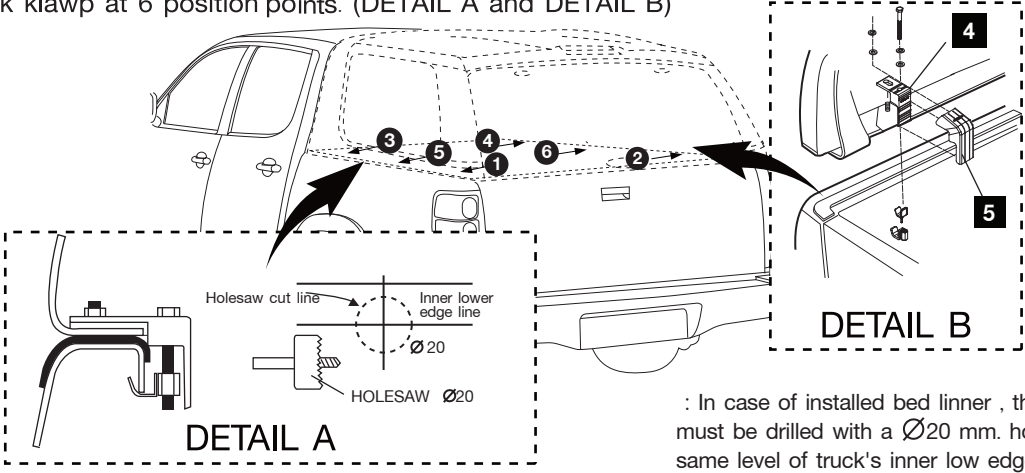

DETAIL A

DETAIL B

: In case of installed bed liner , the bed liner must be drilled with a  $\varnothing 20$  mm. holesaw at the same level of truck's inner low edge.

INSTALLATION G3E

**E** Adjust the position of rear door latches both LH and RH by 13mm. spanner.

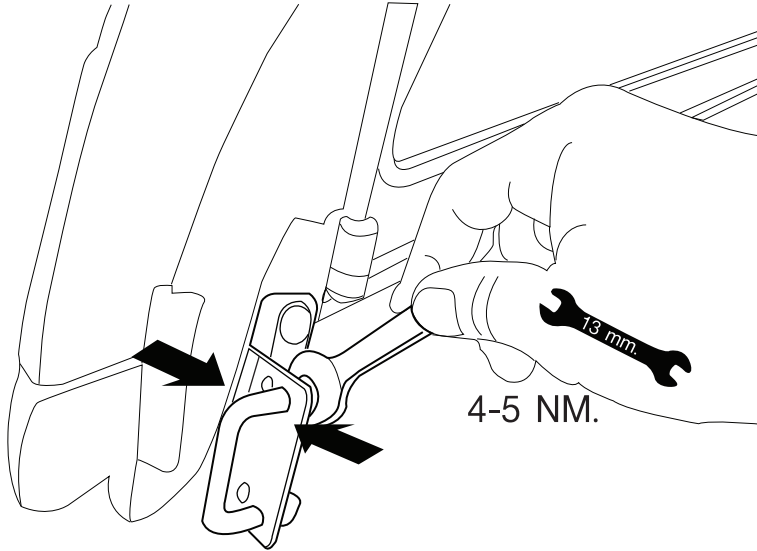

**F** Align and adjust with 2 steps rotary lock system.

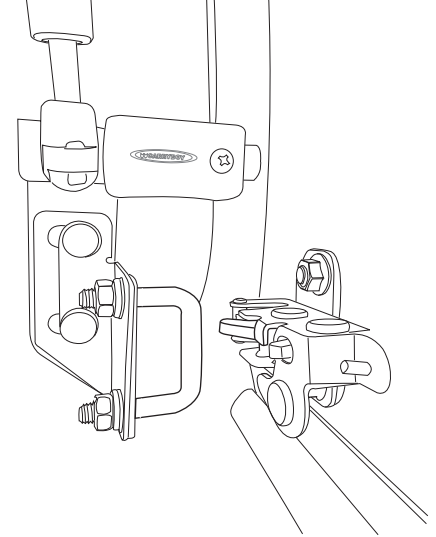

WIRING DIAGRAM

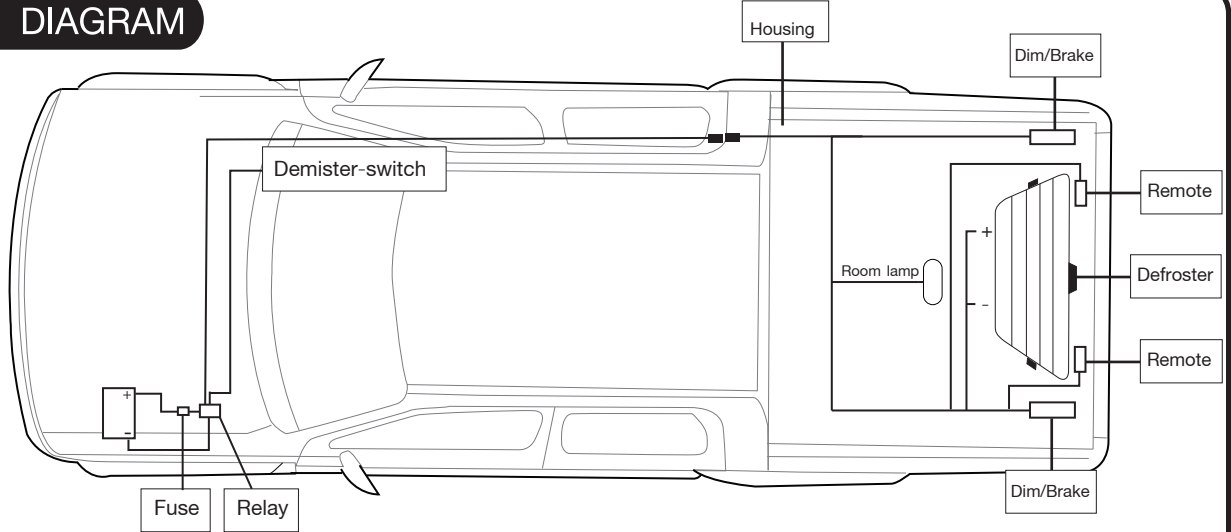

**G** Run the wiring kit and tie up with cable tie provided.

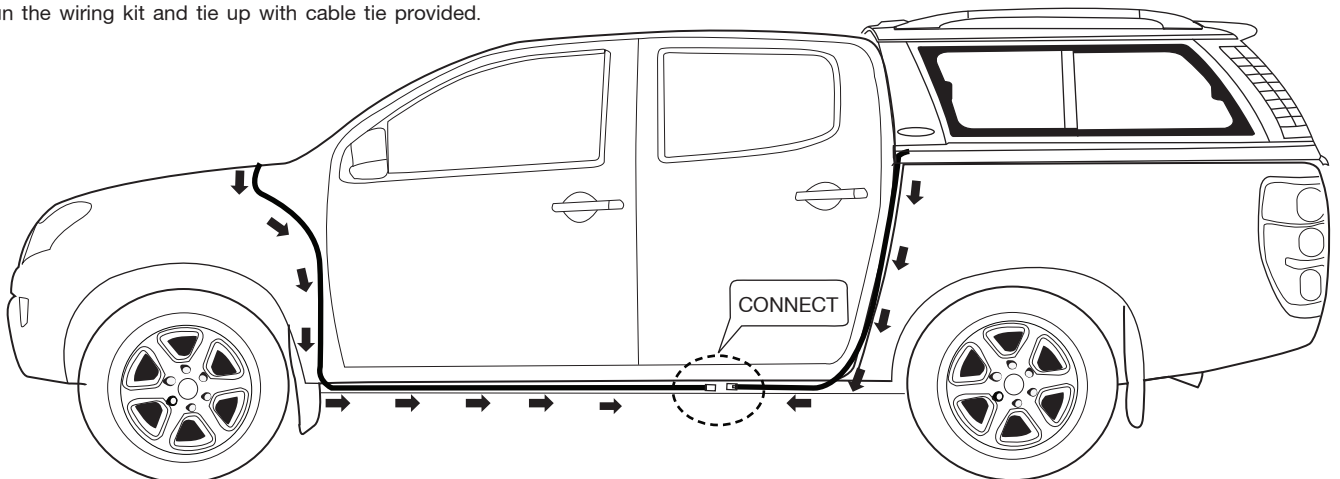

## INSTALLATION G3E

### Demister Wiring Method

- 1** Remove the front console to install the demister switch.

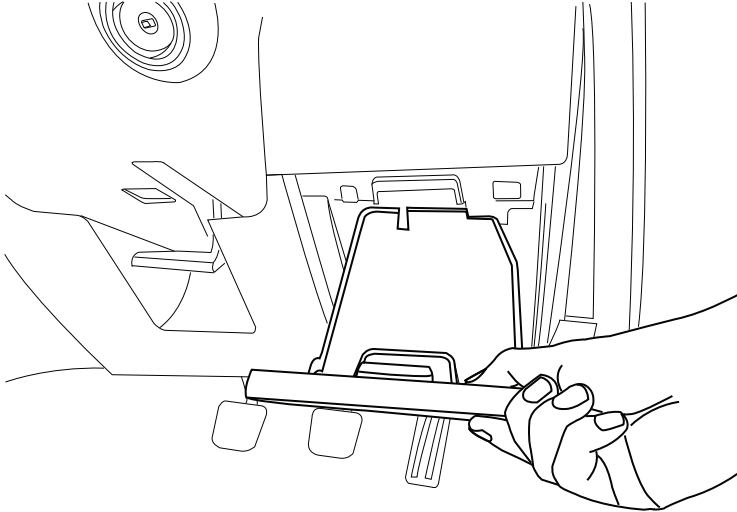

- 2** Remove the boot set both LH and RH.

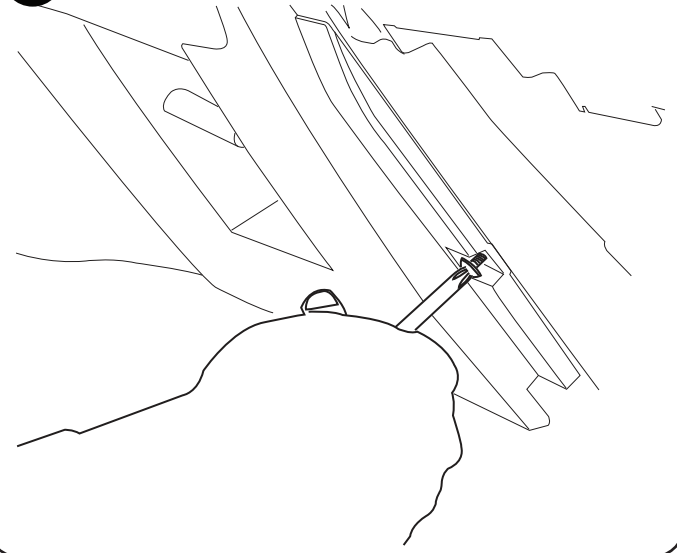

- 3** Insert through the demister switch from the back to the front console and plug it back properly.

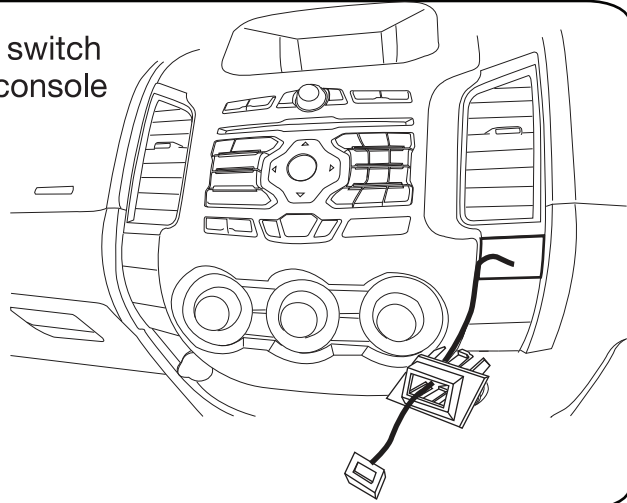

- 4** Run the wiring from the battery through the front bushing hole.

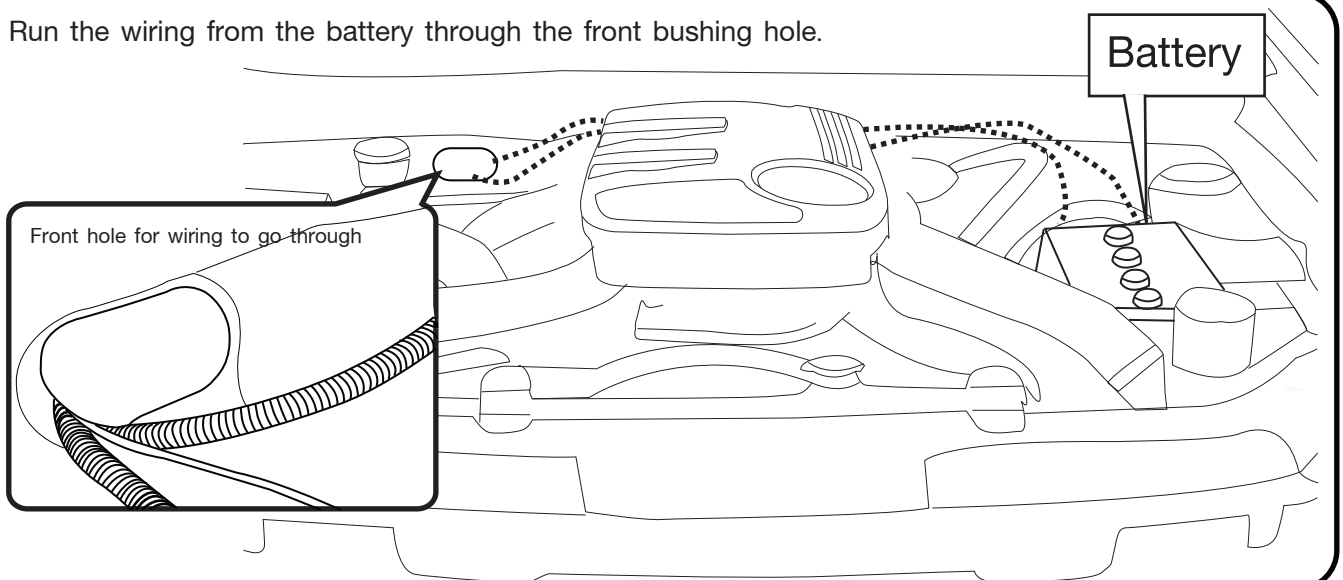

## INSTALLATION G3E

- F** Put the gas strut sticker on as per detail A.  
Install the weatherstrip over the rain channel edge and put along from RH to LH as per detail B.

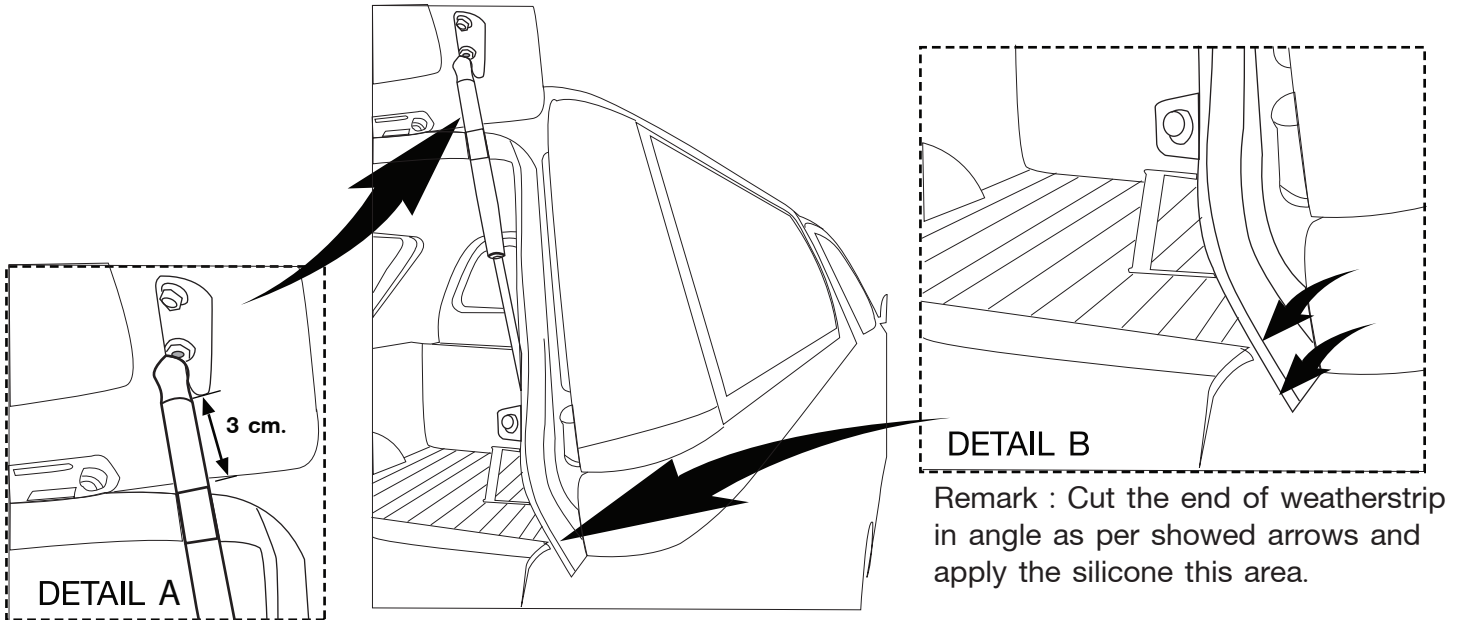

- G** Stick the provided Carryboy resin logo to the same level positions.

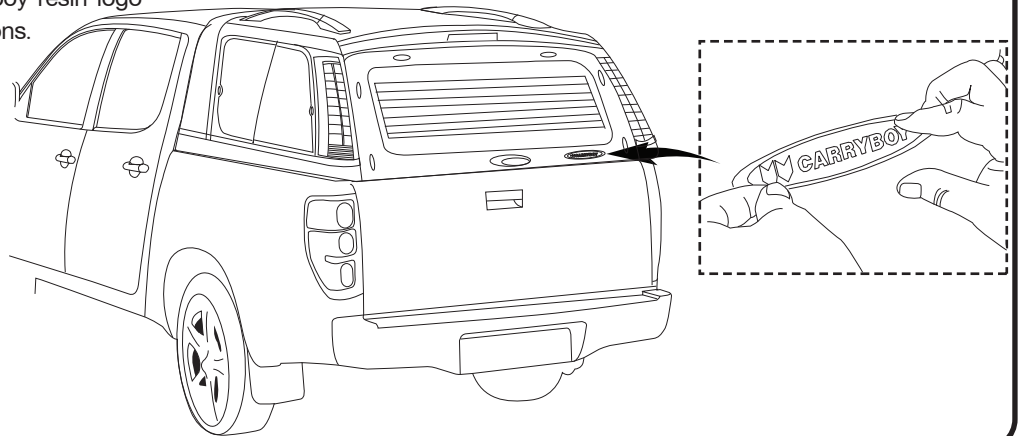

:Recommendation : Adjust and tighten bolts and nuts on the Kwick Klamp every 5,000 kilometers.